

Figure 1. Engineering design of the proposed causeway and associated infrastructure located on DR1602 km 8.4. (Hatch Engineering, 2026).

Should base rock be available for the foundations, the concept engineering design will change as follows:

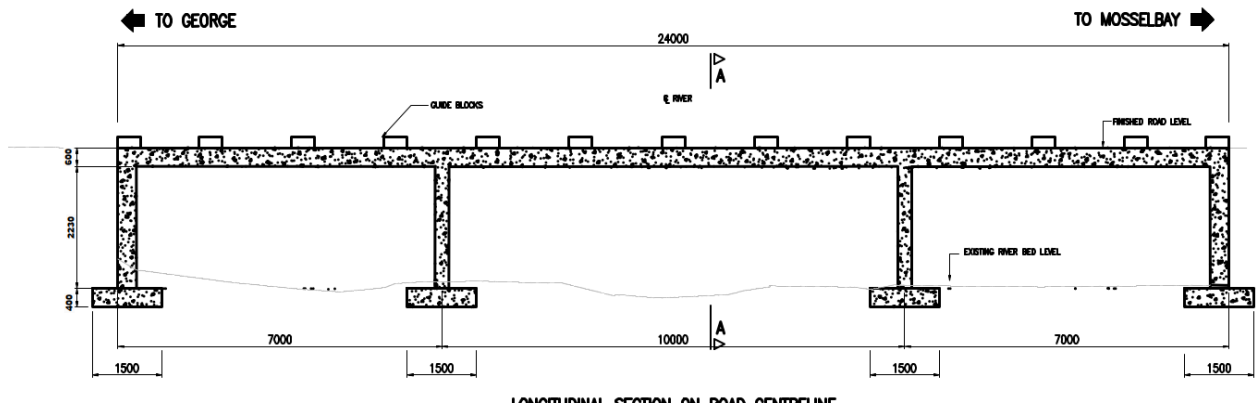

Figure 2. Engineering design of the proposed causeway and associated infrastructure located on DR1602 km 8.4. (Hatch Engineering, 2026).

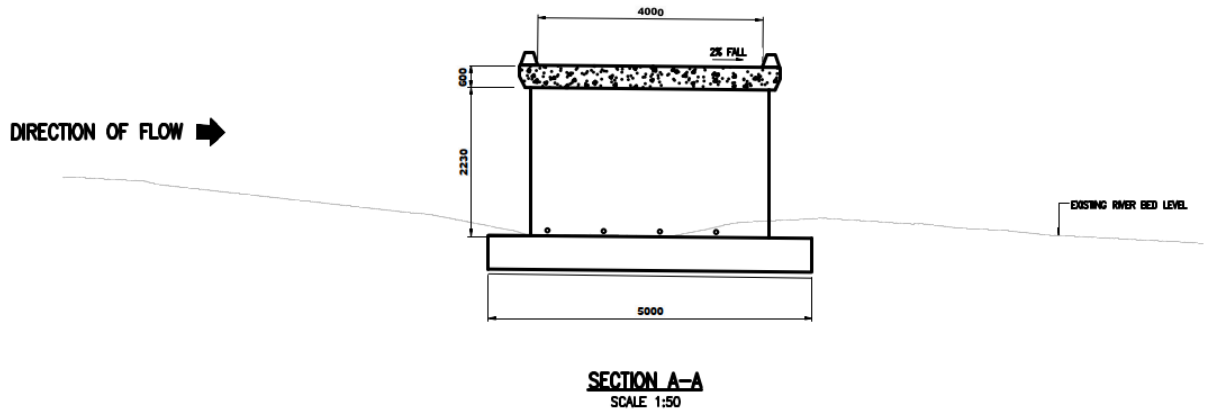

Figure 3. Engineering design of the proposed causeway and associated infrastructure located on DR1602 km 8.4. (Hatch Engineering, 2026).